

## #26 MAXI 2 FLAT

---

- |   |     |                         |
|---|-----|-------------------------|
| 1 | SK  | Montážny návod          |
| 2 | CZ  | Montážní návod          |
| 3 | DE  | Montageanleitung        |
| 4 | ENG | Assembly instructions   |
| 5 | PL  | Instrukcja montażu      |
| 6 | RO  | Instrucțiuni de montaj  |
| 7 | IT  | Istruzioni di montaggio |

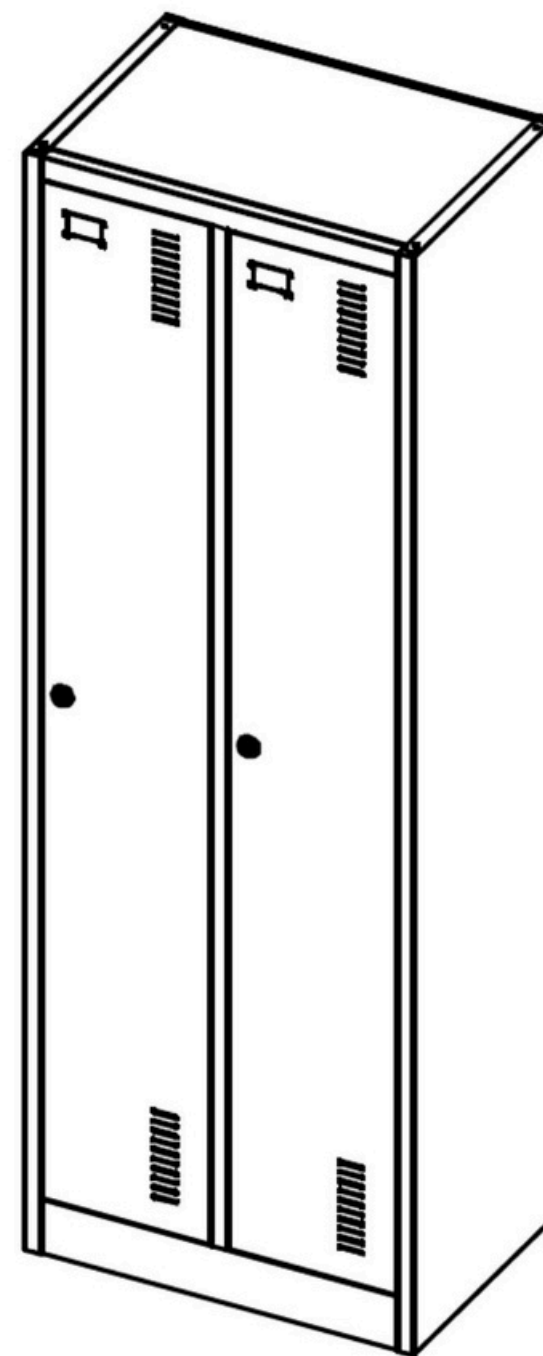



Ľavá strana: 1 ks



Pravá strana: 1 ks



Rám dverí: 1 ks



Zadná doska: 1 ks



Deliaca doska: 1 ks



Deliaca doska: 2 ks



Vrchná doska: 1 ks



Spodná doska: 1 ks

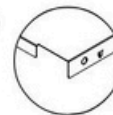

Malé police:  
Ľavá (malá): 1 ks  
Pravá (veľká): 1 ks



Samorezné skrutky (5x10): 19 ks



Kľúče: 2 sety



Háčiky: 8 ks

Vešiaková tyč:  
Krátka: 1 ks  
Dlhá: 1 ks  
Stredná: 2 ks

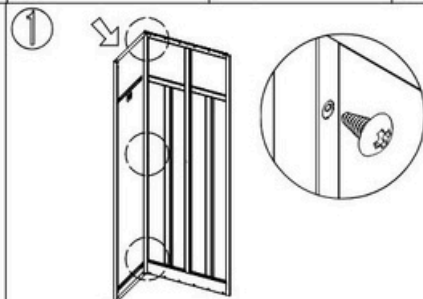
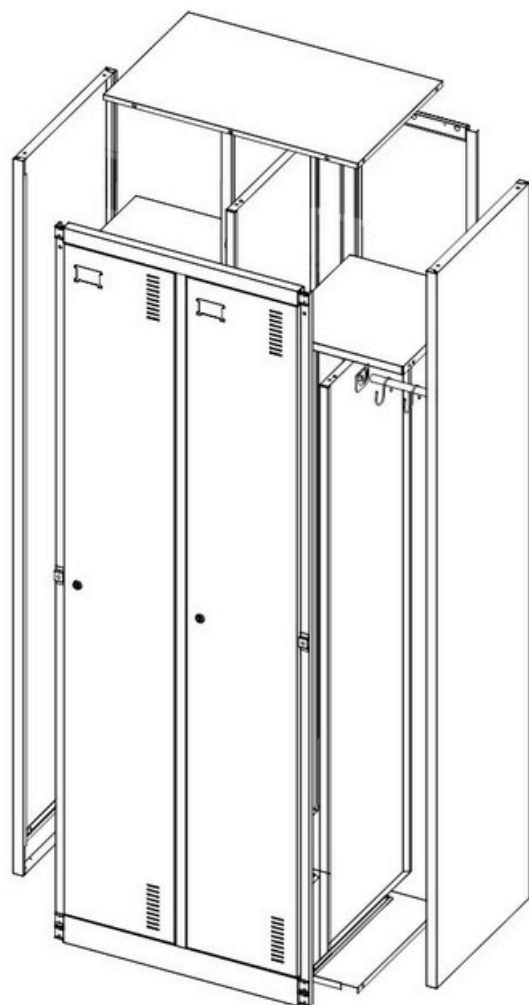

Priskrutkujte ľavú stranu a zadnú dosku samoreznými skrutkami (5x10).

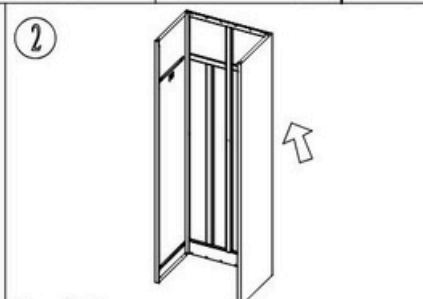

Pravú stranu priskrutkujte k zadnej doske rovnakým spôsobom ako v prvom kroku.

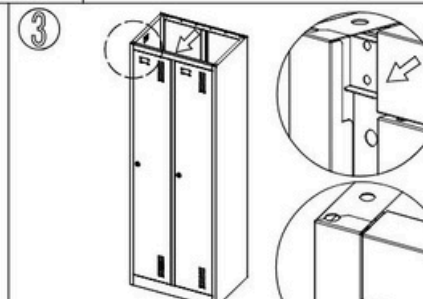

Pripevnite rám dverí na obe bočné dosky.

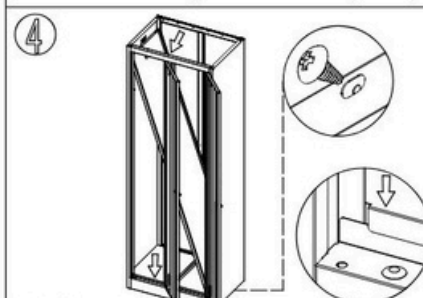

Nainštalujte spodnú dosku a potom upevnite deliacu dosku podľa označenia.

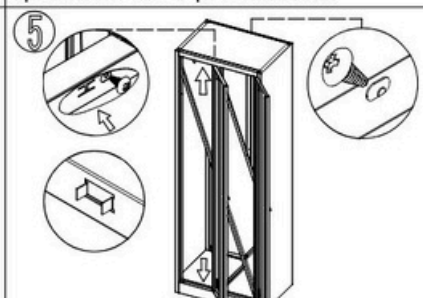

Nainštalujte vrchnú dosku a upevnite ju skrutkami (5x10).

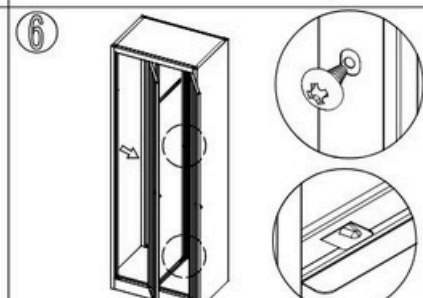

Nainštalujte deliacu dosku podľa označenia.

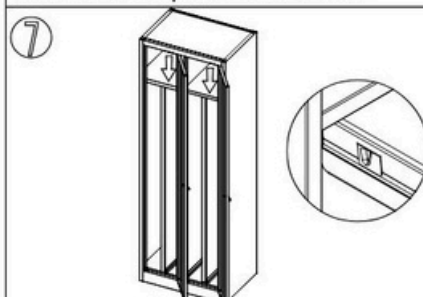

Pripevnite malé police podľa označenia a deliacej dosky.

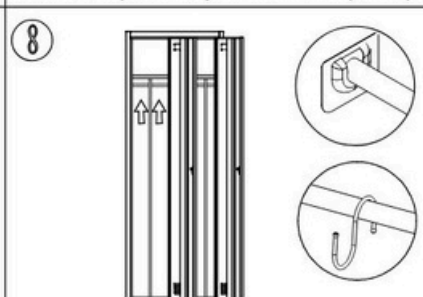

Nainštalujte vešiakovú tyč a háčiky.

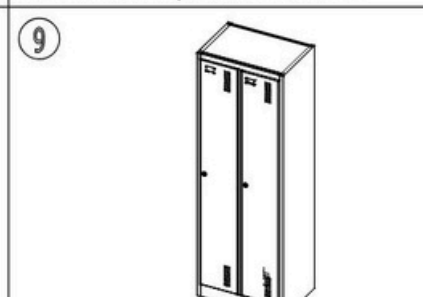

Po inštalácii upravte každú časť tak, aby dobre sedela.



Levá strana: 1 ks



Pravá strana: 1 ks



Rám dveří: 1 ks



Zadní deska: 1 ks



Dělicí deska: 1 ks



Dělicí deska: 2 ks



Vrchní deska: 1 ks



Spodní deska: 1 ks

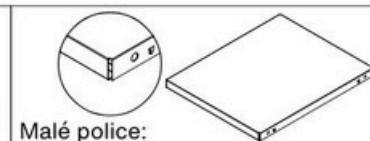
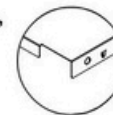

Malé police:  
Levá (malá): 1 ks  
Pravá (velká): 1 ks



Samořezné šrouby  
(5x10): 19 ks



Klíče: 2 sady



Háčky: 8 ks

Věšáková tyč:  
Krátká: 1 ks  
Dlouhá: 1 ks  
Střední: 2 ks

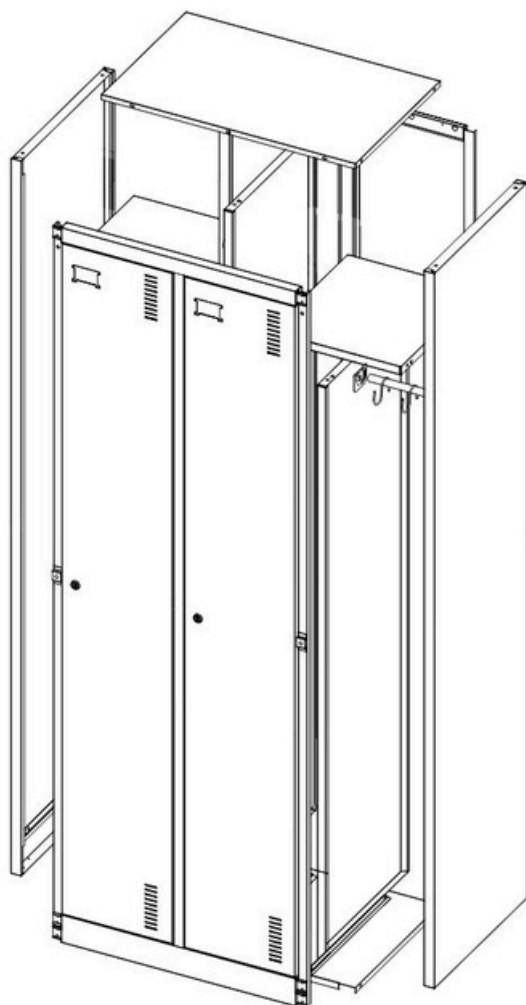

1 Přišroubujte levou stranu a zadní desku samořeznými šrouby (5x10).

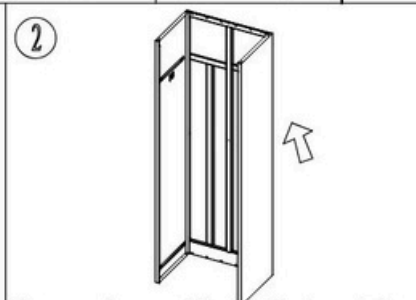

2 Pravou stranu přišroubujte k zadní desce stejným způsobem jako v prvním kroku.

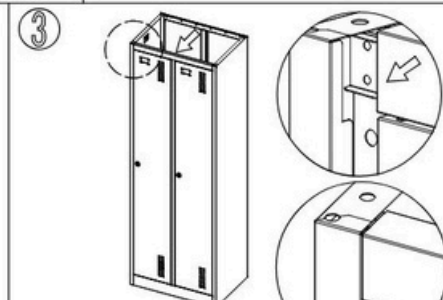

3 Připevněte rám dveří na obě boční desky.

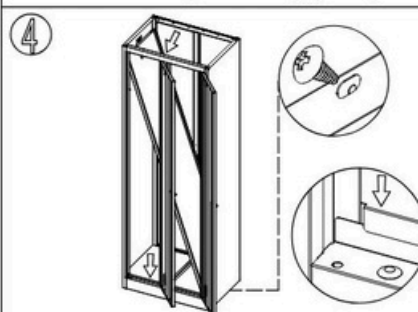

4 Nainstalujte spodní desku a poté upevněte dělicí desku podle označení.

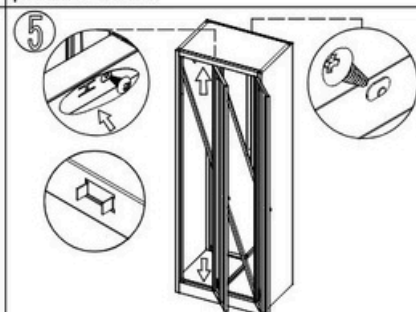

5 Nainstalujte vrchní desku a upevněte ji šrouby (5x10).

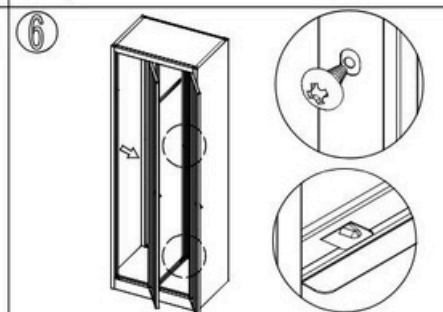

6 Nainstalujte dělicí desku podle označení.

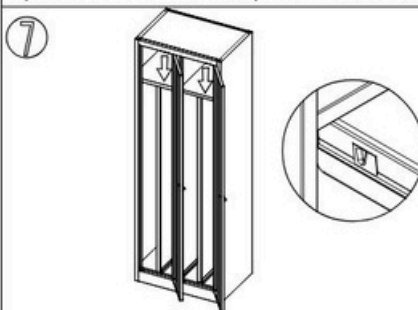

7 Připevněte malé police podle označení a dělicí desky.

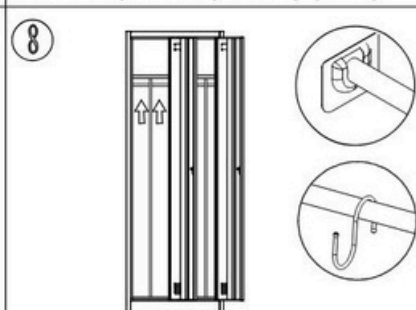

8 Nainstalujte věšákovou tyč a háčky.

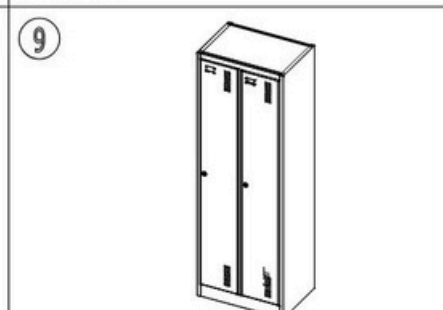

9 Po instalaci upravte každou část tak, aby dobře seděla.

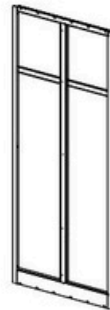

Linke Seite: 1 Stk. Rechte Seite: 1 Stk. Türrahmen: 1 Stk. Rückwand: 1 Stk.



Trennplatte: 1 Stk. Trennplatte: 2 Stk.

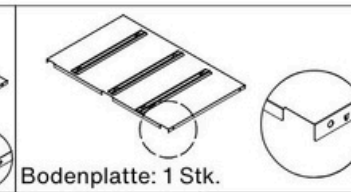
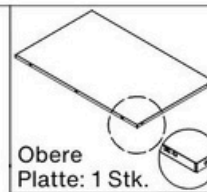

Obere  
Platte: 1 Stk.

Bodenplatte: 1 Stk.



Selbstschneidende  
Schrauben (5x10):  
19 Stk.

Schlüssel: 2 Sets



Haken: 8 Stk.

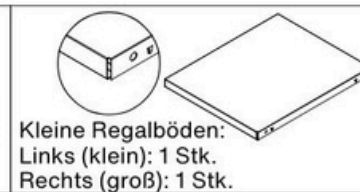

Kleine Regalböden:  
Links (klein): 1 Stk.  
Rechts (groß): 1 Stk.

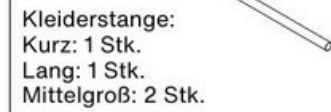

Kleiderstange:  
Kurz: 1 Stk.  
Lang: 1 Stk.  
Mittelgroß: 2 Stk.

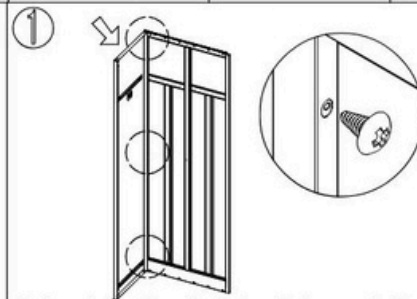
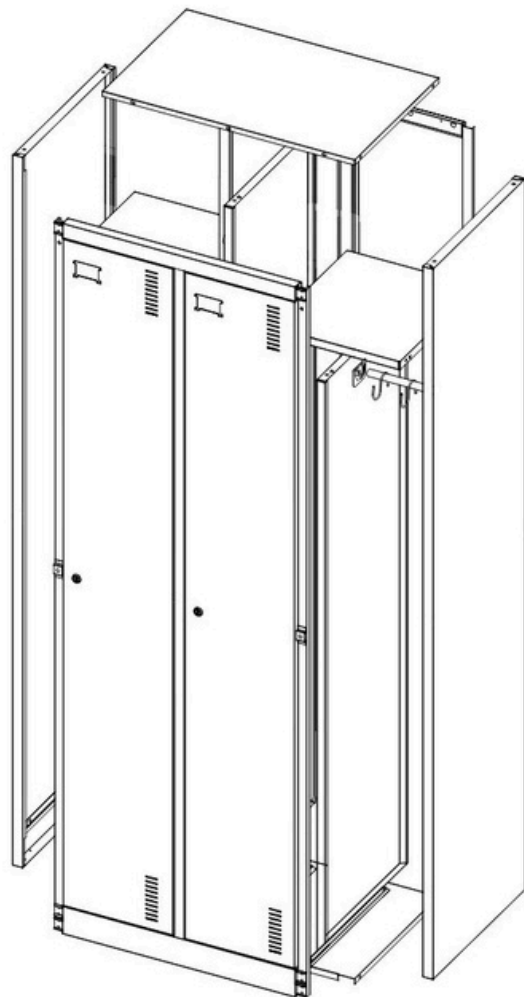

1 Schrauben Sie die linke Seite und die Rückwand mit selbstschneidenden Schrauben (5x10) zusammen.

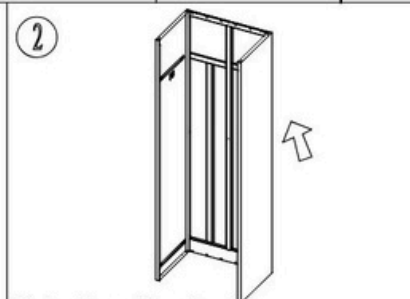

2 Befestigen Sie die rechte Seite auf die gleiche Weise wie im ersten Schritt an der Rückwand.

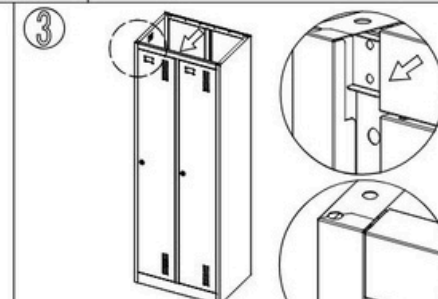

3 Befestigen Sie den Türrahmen an beiden Seitenplatten.

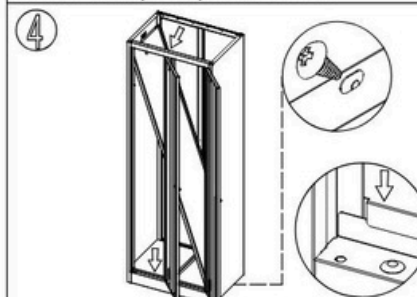

4 Montieren Sie die Bodenplatte und befestigen Sie anschließend die Trennplatte gemäß der Markierung.

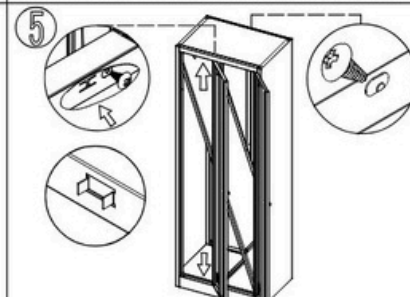

5 Montieren Sie die obere Platte und befestigen Sie sie mit Schrauben (5x10).

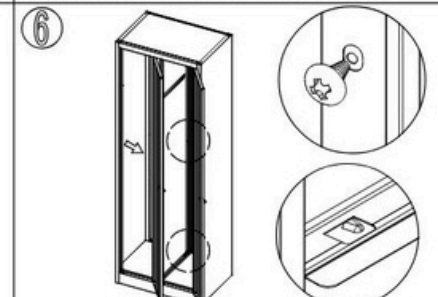

6 Montieren Sie die Trennplatte gemäß der Markierung.

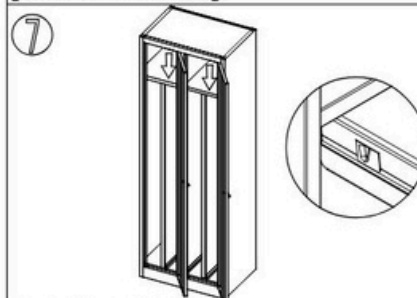

7 Befestigen Sie die kleinen Regalböden gemäß der Markierung und der Trennplatte.

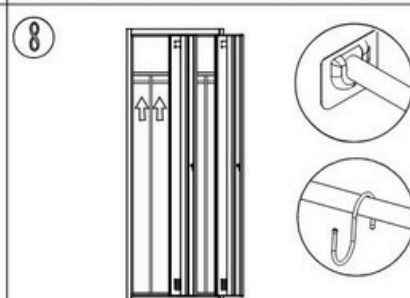

8 Montieren Sie die Kleiderstange und die Haken.

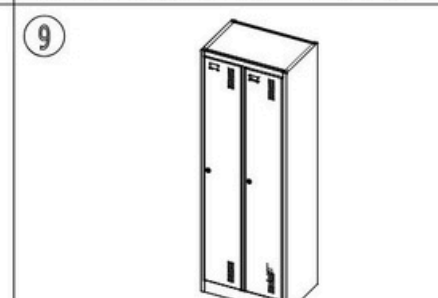

9 Richten Sie nach der Montage alle Teile so aus, dass sie gut sitzen.



Left side: 1 pc



Right side: 1 pc



Door frame: 1 pc



Back plate: 1 pc



Division plate: 1 pc



Division plate: 2 pcs

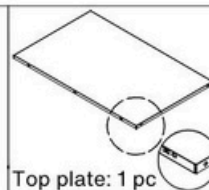

Top plate: 1 pc  
Self-tapping screw (5x10): 19 pcs

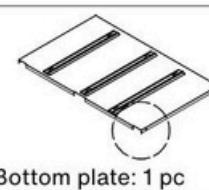

Bottom plate: 1 pc  
Key: 2 sets

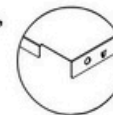

Small shelves:  
Left (small): 1 pc  
Right (big): 1 pc



Hook: 8 pcs

Hanging rod:  
Short size: 1 pc  
Long size: 1 pc  
The middle size: 2 pcs

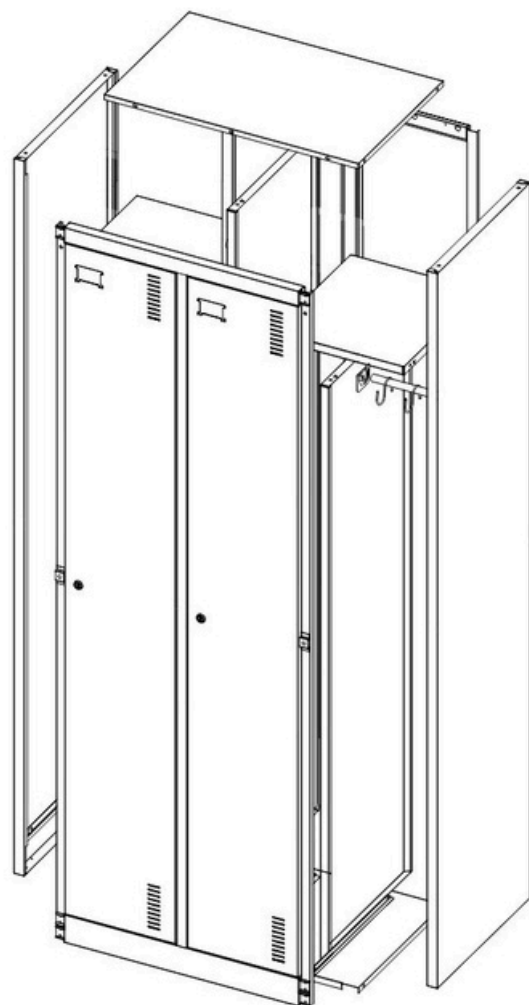

1 Bolt the left side and back plate with self-tapping screws (5x10).

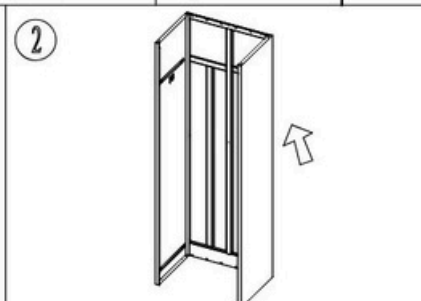

2 Bolt the right side with back plate in the same way as the first step.

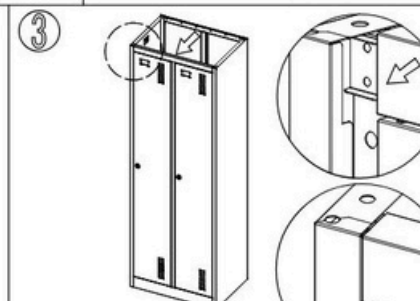

3 Fix the door frame onto both of the side plates.

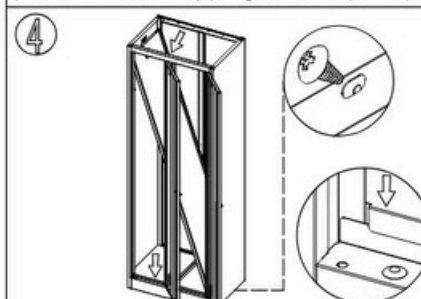

4 Install the bottom plate, then fix the division plate as the sign.

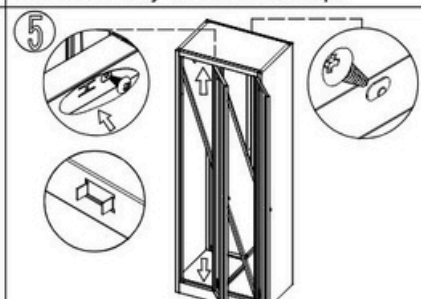

5 Install the top plate and fix with screws (5x10).

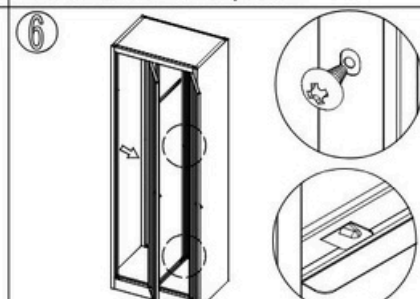

6 Install the divide plate as the sign.

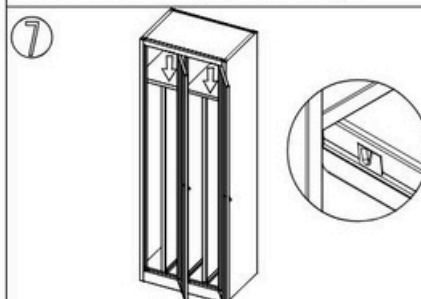

7 Fix the small shelves as the sign and the divide plate.

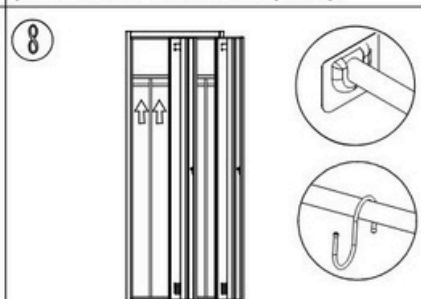

8 Install the hanging rod and hook.

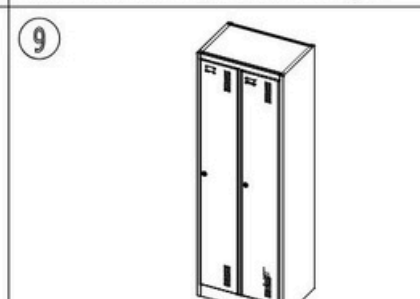

9 Adjust each part till fit well after installation.



Lewa strona: 1 szt. Prawa strona: 1 szt. Rama drzwi: 1 szt. Tylna płyta: 1 szt.



Płyta dzieląca: 1 szt.



Płyta dzieląca: 2 szt.

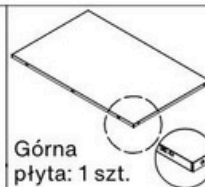

Górna płyta: 1 szt.



Dolna płyta: 1 szt.

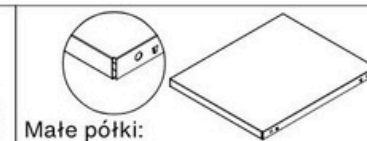
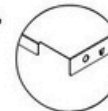

Małe półki:  
Lewa (mała): 1 szt.  
Prawa (duża): 1 szt.



Wkręty samogwintujące (5x10): 19 szt.



Klucze: 2 zestawy



Haczyki: 8 szt.

Drażek do wieszania ubrań:  
Krótki: 1 szt.  
Długi: 1 szt.  
Średni: 2 szt.

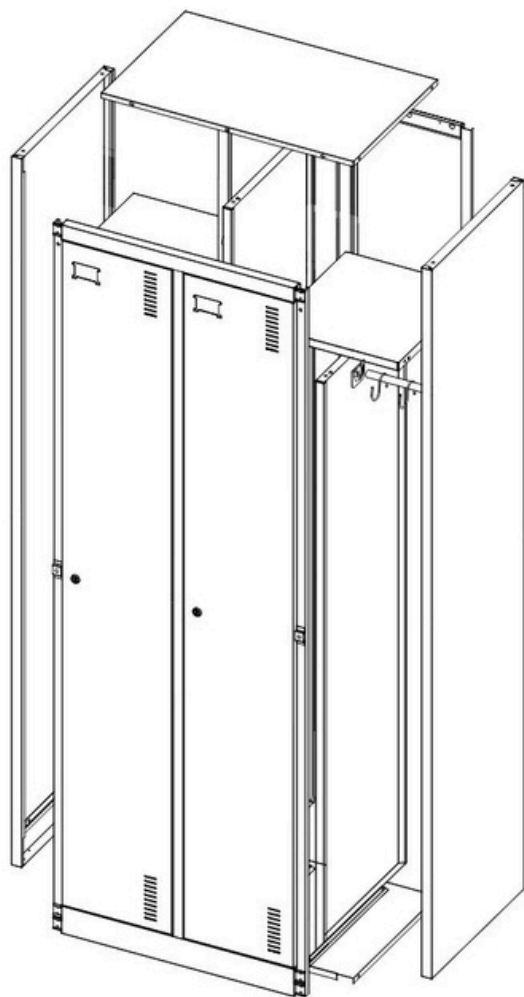

1 Przykręć lewą stronę i tylną płytę za pomocą wkrętów samogwintujących (5x10).

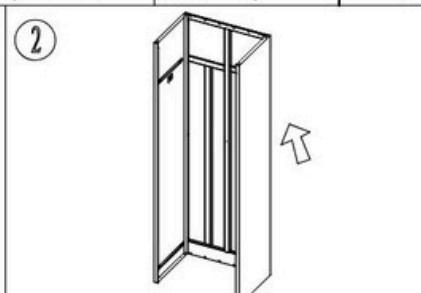

2 Przykręć prawą stronę do tylnej płyty w taki sam sposób jak w pierwszym kroku.

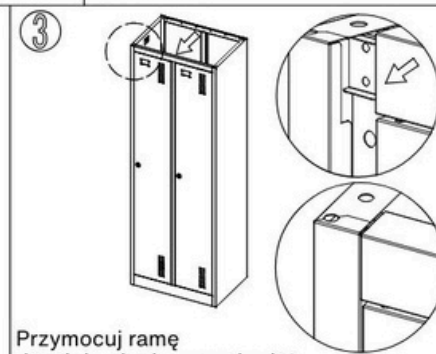

3 Przymocuj ramę drzwi do obu bocznych płyt.

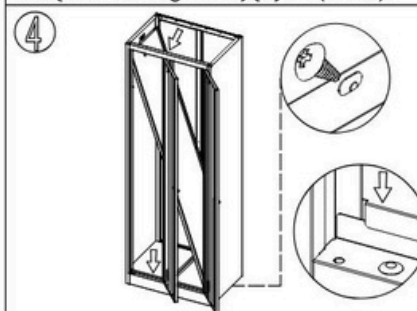

4 Zamontuj dolną płytę, a następnie przymocuj płytę dzielącą zgodnie z oznaczeniem.

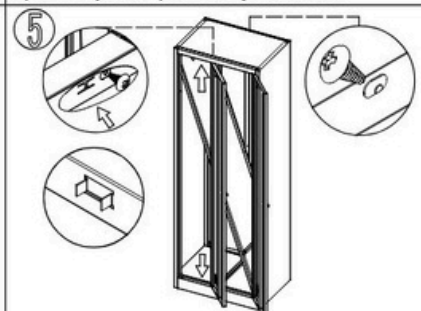

5 Zamontuj górną płytę i przymocuj ją śrubami (5x10).

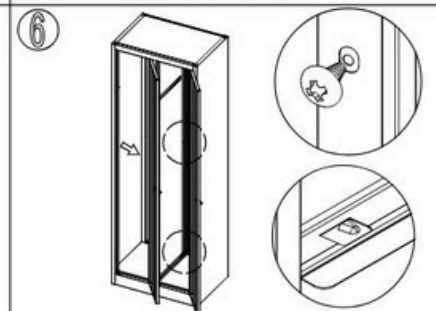

6 Zamontuj płytę dzielącą zgodnie z oznaczeniem.

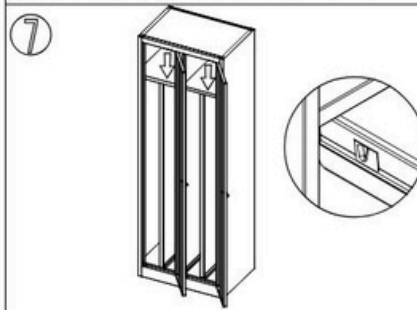

7 Przymocuj małe półki zgodnie z oznaczeniem i płytą dzielącą.

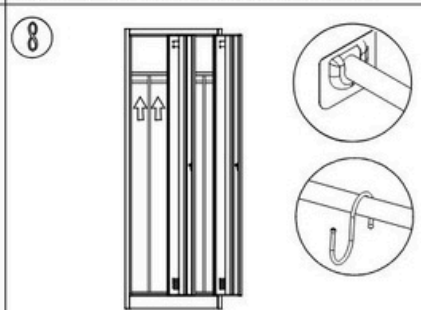

8 Zamontuj drążek do wieszania ubrań i haczyki.

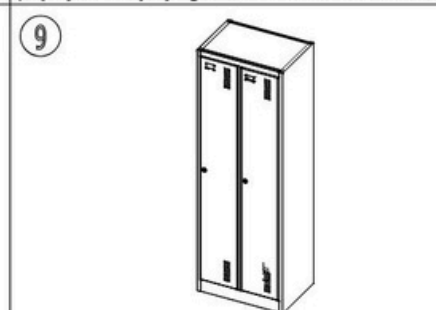

9 Po montażu wyreguluj wszystkie części tak, aby dobrze pasowały.



Partea stângă: 1 buc.



Partea dreaptă: 1 buc.



Rama uşii: 1 buc.



Panoul din spate: 1 buc.



Panou despărţitor: 1 buc.



Panou despărţitor: 2 buc.

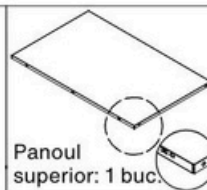

Panoul superior: 1 buc.

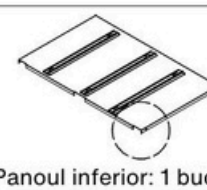

Panoul inferior: 1 buc.

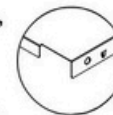

Rafturi mici:  
Stânga (mic): 1 buc.  
Dreapta (mare): 1 buc.



Şuruburi autofiletante (5x10): 19 buc.



Chei: 2 seturi



Cârlige: 8 buc.

Bară pentru agăţarea hainelor:  
Scurtă: 1 buc.  
Lungă: 1 buc.  
Medie: 2 buc.

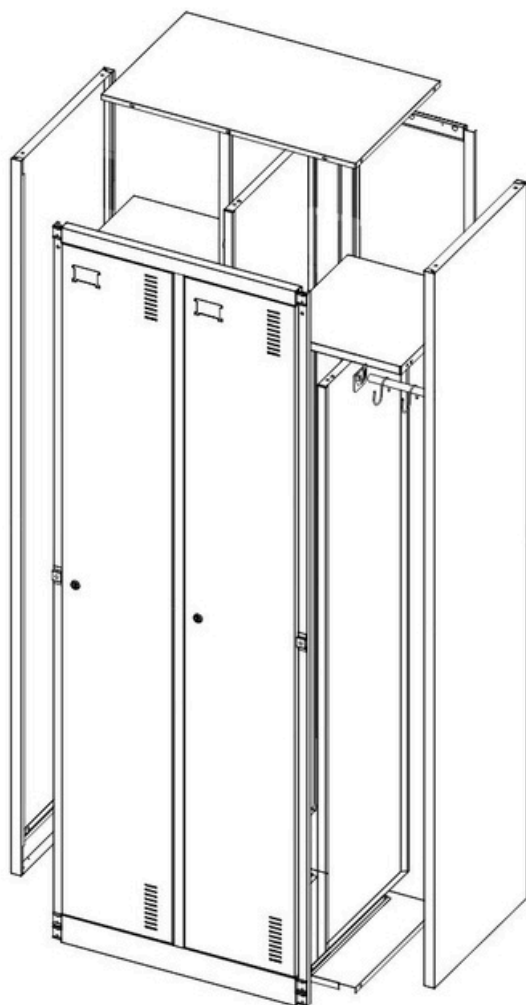

1 Înşurubaţi partea stângă şi panoul din spate folosind şuruburi autofiletante (5x10).

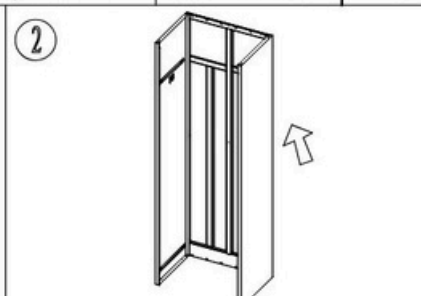

2 Fixaţi partea dreaptă de panoul din spate în acelaşi mod ca la primul pas.

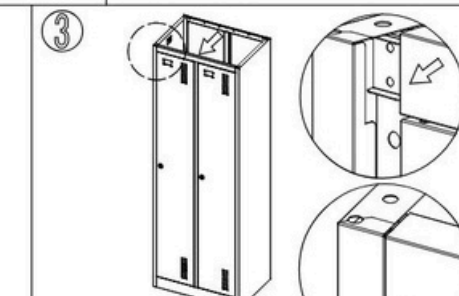

3 Fixaţi rama uşii pe ambele panouri laterale.

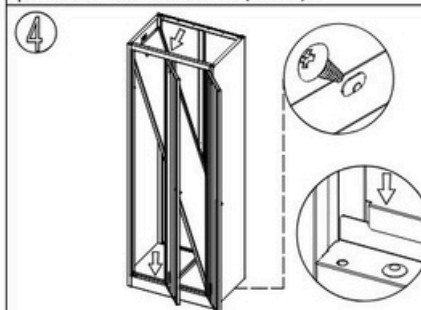

4 Instalaţi panoul inferior, apoi fixaţi panoul despărţitor conform marcajului.

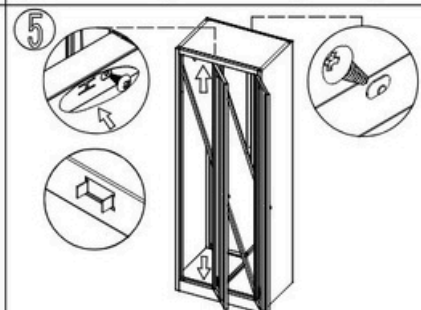

5 Instalaţi panoul superior şi fixaţi-l cu şuruburi (5x10).

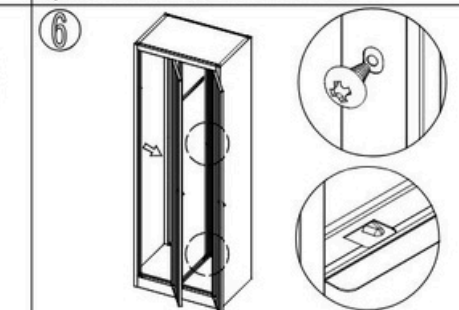

6 Instalaţi panoul despărţitor conform marcajului.

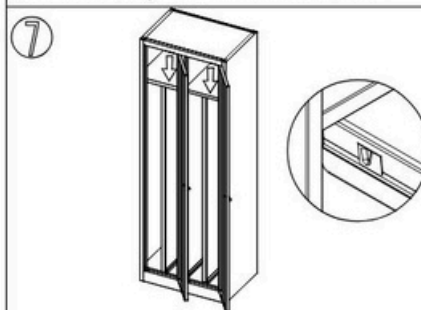

7 Fixaţi rafturile mici conform marcajului şi panoului despărţitor.

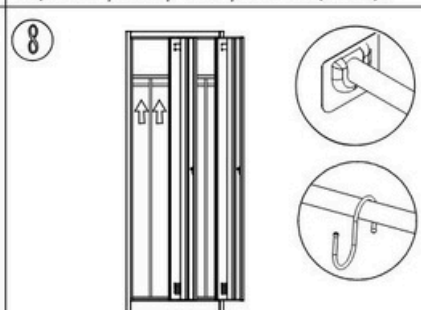

8 Instalaţi bara pentru haine şi cârligele.

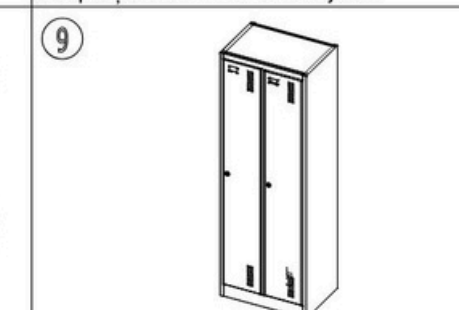

9 După instalare, ajustaţi fiecare parte astfel încât să se potrivească bine.



Lato sinistro: 1 pz



Lato destro: 1 pz



Telaio della porta: 1 pz



Pannello posteriore: 1 pz



Pannello divisorio: 1 pz



Pannello divisorio: 2 pz

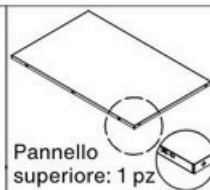

Pannello superiore: 1 pz

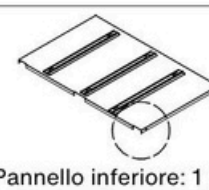

Pannello inferiore: 1 pz

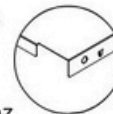

Piccoli ripiani:  
Sinistra (piccola): 1 pz  
Destra (grande): 1 pz



Viti autofilettanti (5x10): 19 pz



Chiavi: 2 set



Ganci: 8 pz

Barra appendiabiti:  
Corta: 1 pz  
Lunga: 1 pz  
Media: 2 pz

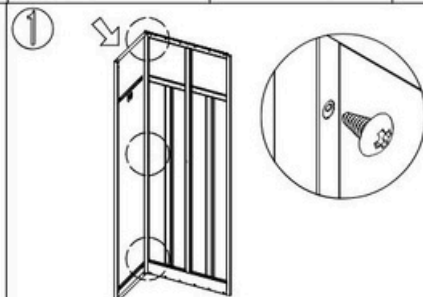
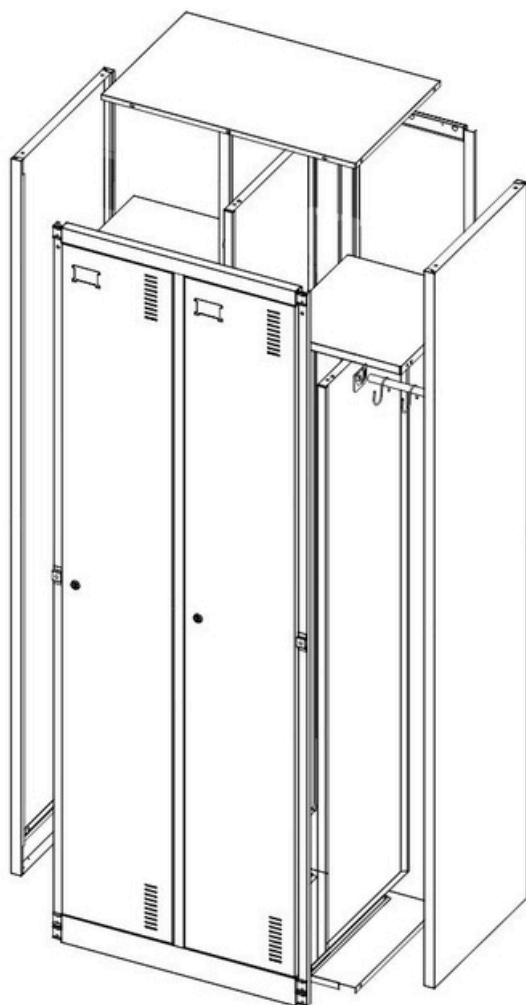

1 Avvitare il lato sinistro e il pannello posteriore utilizzando viti autofilettanti (5x10).

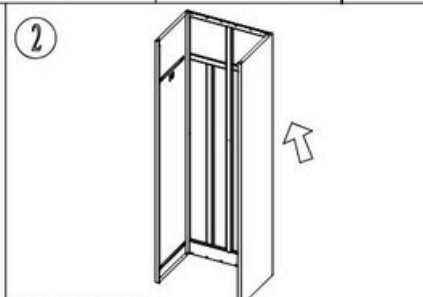

2 Fissare il lato destro al pannello posteriore nello stesso modo del primo passaggio.

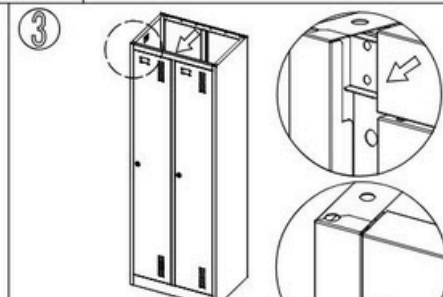

3 Fissare il telaio della porta a entrambi i pannelli laterali.

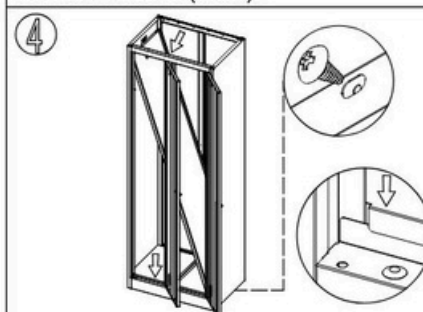

4 Installare il pannello inferiore e quindi fissare il pannello divisorio come indicato.

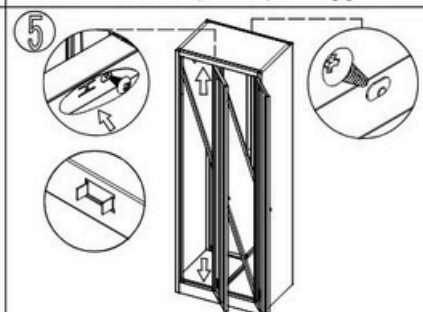

5 Installare il pannello superiore e fissarlo con viti (5x10).

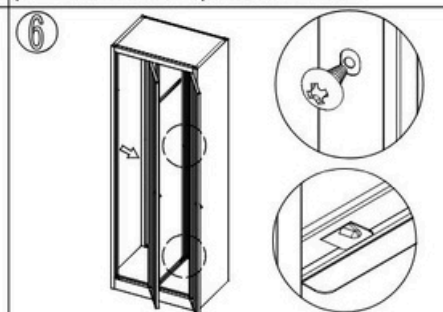

6 Installare il pannello divisorio come indicato.

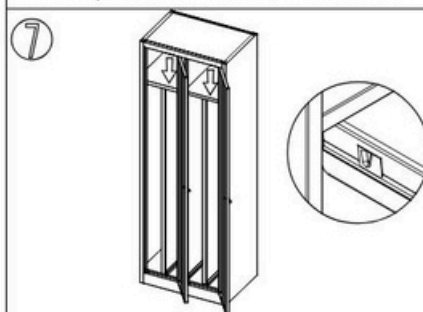

7 Fissare i piccoli ripiani come indicato e il pannello divisorio.

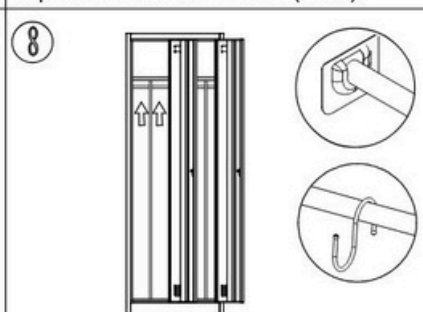

8 Installare la barra appendiabiti e i ganci.

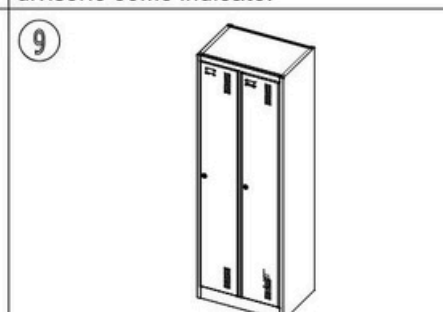

9 Dopo l'installazione, regolare ogni parte in modo che si adatti correttamente.